

## Flow Measurement

### SITRANS F C

#### Flow sensor MC2

##### Overview



SITRANS F C MC2 is available in sizes DN 100 and DN 150 (4" and 6").

The MC2 sensor is suitable for accurate mass flow measurement of a variety of liquids.

The sensor offers superior performance in terms of flow accuracy, turn-down ratio and density accuracy and delivers true multi-parameter measurements i.e.: mass flow, volume flow, density, temperature and fraction flow.

The very compact sensor construction makes installation and commissioning of even the largest sizes very straight forward and easy.

##### Benefits

- High accuracy better than 0.15 % of mass flow rate
- Large dynamic turn-down ratio
- Densitometer performance available through density accuracy better than  $0.001 \text{ g/cm}^3$
- Space-saving split-flow sensor design facilitating low pressure loss
- Parallel S-tube design and optimal oriented inductive sensors enhances accuracy and turn-down ratio.
- Self-draining in both horizontal and vertical position
- Rigid enclosure design reduces the influence from pipeline vibration and thermal stress
- 4-wire Pt100 temperature measurement ensures optimum accuracy on mass flow, density and fraction flow
- SENSORPROM enables true "plug & play" - installed and commissioned in less than 10 minutes.
- Safe Ex design
- Sensor pipe available in high-quality stainless steel AISI 316Ti/1.4571 or Hastelloy C4/2.4610 offering optimum corrosion resistance.
- CIP cleanability for food and beverage and pharmaceutical applications

##### Application

Coriolis mass flowmeters are suitable for measuring all liquids. The measurement is independent of changes in process conditions/parameters such as temperature, density, pressure, viscosity, conductivity, and flow profile.

Due to this versatility the meter is easy to install and the Coriolis flowmeter is recognized for its high accuracy in a wide turndown ratio which is paramount in many applications.

MC2 sensors are not designed or approved for flow measurement of gaseous process media.

The product is manufactured by ABB Automation Products GmbH and distributed by Siemens.

##### The main applications of the Coriolis flowmeter can be found in all industries, such as:

<b>Chemical and pharma</b>	Detergents, bulk chemicals, pharmaceuticals, acids, alkalis
<b>Food and beverage</b>	Dairy products, beer, wine, soft-drinks, Plato/Brix, fruit juices and pulps, bottling, CO <sub>2</sub> dosing, CIP-liquids
<b>Oil and gas</b>	Liquid measurement, furnace control, test separators, LPG, oil bunkering
<b>Water and waste water</b>	Dosing of chemicals for water treatment

The wide variety of combinations and versions from the modular system means that ideal adaptation is possible to each measuring task. MC2 is **not** recommended for gas applications.

##### Design

The MC2 sensor consists of 2 parallel measuring pipes, welded directly onto a flow-splitter at each end to eliminate a direct coupling to the process connectors and significantly reduce effects from external vibrations.

The flow-splitters are welded onto a rigid sensor housing which acts as a mechanical low-pass filter.

The sensor is available in 2 material configurations, AISI 316L/1.4436 or Hastelloy C4/2.4610 with a wide variety of process connections.

The enclosure is made of stainless steel AISI 304/1.4301 with an encapsulation grade of IP67/NEMA 4.

The sensor is Ex-approved.

It can be installed in horizontal or vertical position, and is self-draining in both positions.

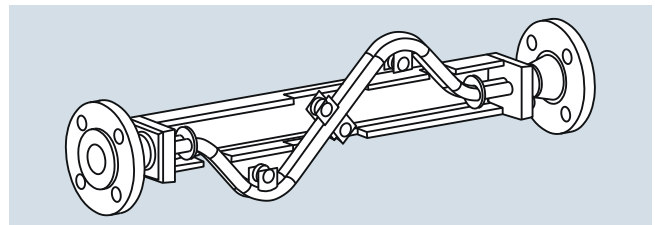

The MC2 Ex version sensor is based on a different Ex concept than MASS 6000. Therefore the MC2 Ex version sensor can only be connected to MASS 6000 IP67, MASS 6000 19" or SIFLOW FC070 standard versions, which have to be remote mounted in the safe area. MASS 6000 Ex d, MASS 6000 19" Ex and SIFLOW FC070 Ex can **not** be used with MC2 Ex sensors.



Hazardous area  
Zone 1 + 2



Safe area

**Function**

The measuring principle is based on the Coriolis effect. See "System information Coriolis mass flowmeters".

**Integration**

**Installation guidelines MC2 DN 100 and DN 150**

Installation of sensor

Rigid mounting brackets must be used when installing the sensor. The brackets must be installed as close to the sensor as possible, attached to the piping outside the process connections.

The optimal installation orientation is a vertical installation with an upward flow as shown in the following figure. This has the advantage that any solids contained in the fluid will settle downward and gas bubbles will move upward out of the meter tube when the flow rate is zero. Additionally, it is easy to drain the meter tube. Deposits can thereby be avoided.

Vertical orientation:

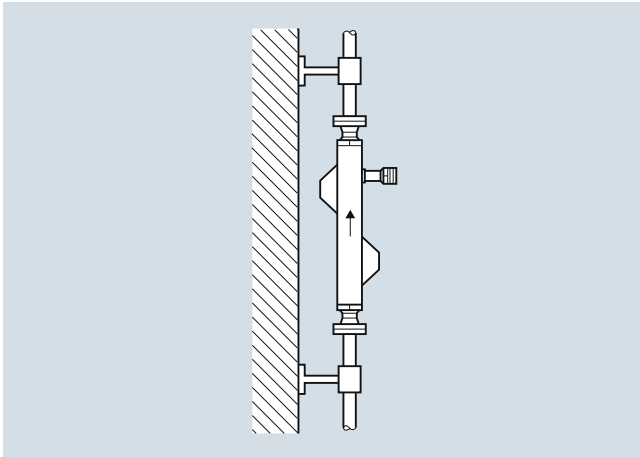

Vertical installation self-draining (upward flow)

Horizontal orientation, self-draining

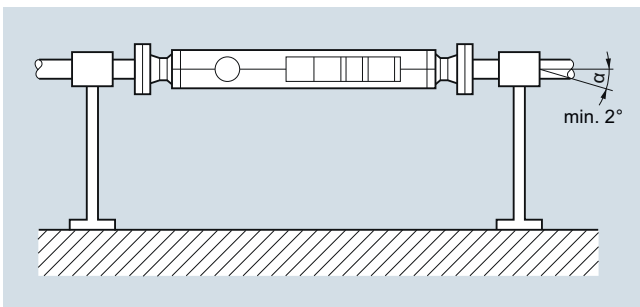

Avoid vibrations

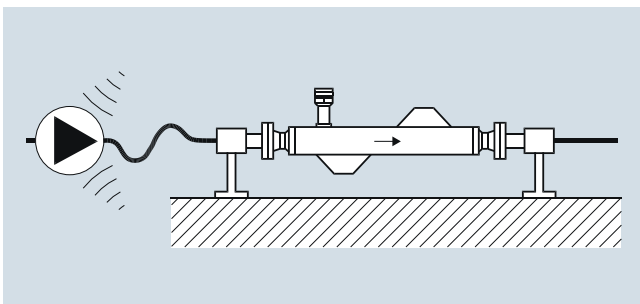

Avoid cross talk

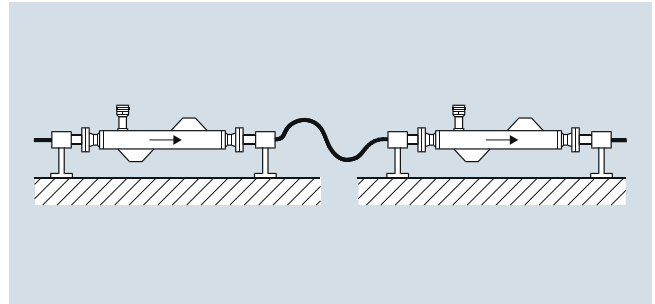

Installation in a drop line

Mount with reduction (A) or orifice (B) to prevent partially draining (min. back pressure: 0.2 bar).

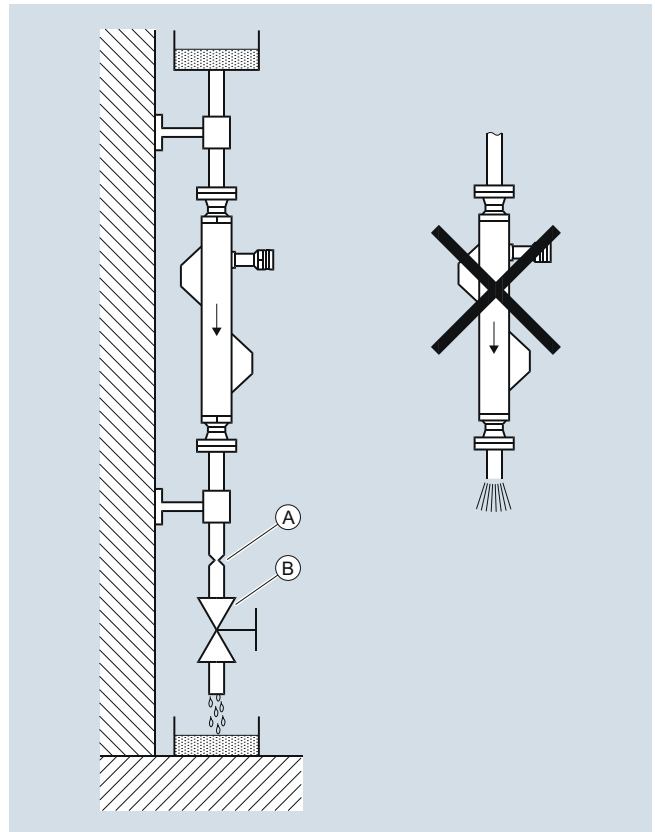

Installation in a drop line

## Flow Measurement

### SITRANS F C

#### Flow sensor MC2

#### Technical specifications

Versions (mm (inch))		100 (4)	150 (6)
<b>Inside pipe diameter</b>	mm (inch)	43.1 (1.69)	76.1 (2.99)
<b>Pipe wall thickness</b>	mm (inch)	2.6 (0.10)	3.2 (0.13)
<b>Mass flow measuring range at pressure drop of 2 bar (29 psi) at 1 g/cm<sup>3</sup> (0.036 lb/inch<sup>3</sup>)</b>	kg/h (lb/h)	203 500 (448 640)	602 000 (1 327 181)
<b>Density</b>	g/cm <sup>3</sup> (lb/inch <sup>3</sup> )	0.5 ... 3.5 (0.18 ... 0.126)	
<b>Fraction e.g. Brix</b>	°Brix	0 ... 100 (on request)	Not possible
<b>Temperature</b>			
Standard-version		-50 ... +200 °C (-58 ... +392 °F)	
Ex-version		-50 ... +200 °C (-58 ... +392 °F)	
<b>Liquid pressure measuring pipe</b>			
Stainless steel (DIN 2413, 20 °C (68 °F))	<b>bar (psi)</b>	40 (580)	40 (580)
<b>Materials</b>			
Measuring pipe		Stainless steel AISI 316Ti/1.4571 or Hastelloy C4/2.4610	
<b>Enclosure</b>			
Enclosure material/ connection box		IP67 AISI 304 (1.4301)/aluminum, max. pressure 40 bar (580 psi)	
<b>Process connections</b>			
Electrical connections		See dimensional drawings Screw terminals, M 20	
Cable		5 x 2 x 0.35 mm <sup>2</sup> twisted and screened in pairs, ext. Ø 12 mm	
Cable length		10, 25, 75 or 150 m (32.8, 82, 246 or 492 ft.)	
<b>Ex-version</b>			
ATEX		II 1/2 G Ex e m d [ia] IIC T6 ... T2 II 2 D Ex tD A21 IP6X T115°C ... Tfluid	
<b>Weight approx.</b>	<b>kg (lb)</b>	91 (201)	261 (573)

For accuracy specifications see „System information Coriolis mass flowmeters“.

#### Pressure drop

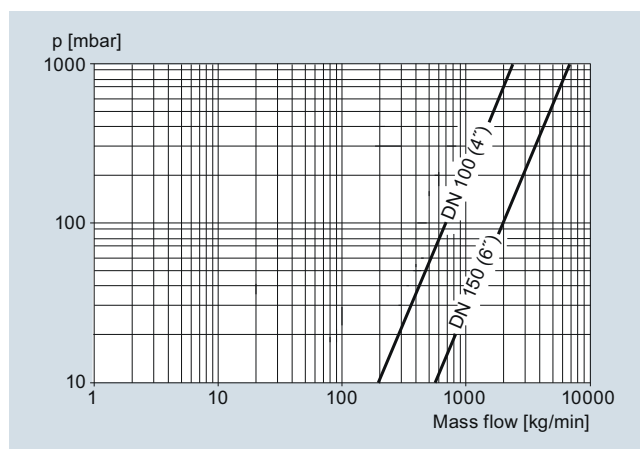

Selection and Ordering data	Article No.	Ord. code
<b>SITRANS F C flow sensors MC2</b>	7ME4300-	
<p>Click on the Article No. for the online configuration in the PIA Life Cycle Portal.</p>		
<b>Nominal diameter</b>		
Stainless steel AISI 316Ti/1.4571		
DN 100	1 D	
DN 150	1 E	
Hastelloy C4/2.4610		
DN 100	2 D	
<b>Nominal pressure</b>		
PN 40	A	
Class 150	C	
Class 300	D	
Clamps/screwed-connections	F	
<b>Process connections</b>		
Flange EN 1092-1		
DN 80 (PN 40, PN 100)	2 2	
DN 100 (PN 40)	2 3	
DN 150 (PN 40)	2 4	
Flange ASME/ANSI B16.5		
3" (class 150/300/600)	3 2	
4" (class 150/300)	3 3	
6" (class 150/300)	3 4	
Dairy screwed connection to DIN 11851		
DN 80 (PN 25)	4 2	
DN 100 (PN 25)	4 3	
Dairy clamp connection DIN 32676 (ISO 2852) Tri-clamp		
81 mm clamp (PN 10)	5 2	
100 mm clamp (PN 10)	5 3	
Aseptic nut flange DIN 11864-2 form A for pipes dimensioned by DIN 11866		
DN 80 (3")	6 3	
DN 100 (4")	6 4	
<b>Configuration</b>		
Flow (0.15% of rate) and density (5 kg/m <sup>3</sup> [0.31 lb/ft <sup>3</sup> ])	1	
Flow (0.15% of rate) and density (1 kg/m <sup>3</sup> [0.06 lb/ft <sup>3</sup> ])	5	
<b>Ex-approval and cable gland</b>		
Non-Ex, M20 x 1.5	A	
Ex, M20 x 1.5	B	
<b>Cable</b>		
No cable	A	
<b>Calibration</b>		
(Density and fraction calibrations must be ordered as PVR)		
Standard	1	

**Dairy MLFB example MC2 sensor**

Sensor size DN 100. AISI 316Ti/1.4571  
Nominal pressure: Clamps  
DIN 11851, DN 100, PN 25



Configuration/calibration type: flow and density (5 kg/m<sup>3</sup> [0.31 lb/ft<sup>3</sup>])  
Without Ex approval  
No cable  
Standard calibration

Article No.
7ME4300-
1 D
F
4 3
1
A
1

**Selection and Ordering data**

Order code

**Additional information**

Please add "-Z" to Article No. and specify Order code(s) and plain text.

Pressure testing certificate PED: 2014/68/EU

C11

Material certificate EN 10204-3.1

C12

Material certificate according to NACE

C16

Tag name plate, stainless steel

Y17

Tag name plate, plastic self-adhesive

Y18

Customer-specified, matched pair (5 x 2)

On request

Customer-specified calibration (5 x 2)

On request

Customer-specified, matched pair (10 x 1)

On request

Customer-specified calibration (10 x 1)

On request

**Operating instructions for SITRANS F C MC2**

This device is shipped with ABB documentation and an installation/connection instruction in four languages (Article No. A5E34730442).

All literature is available to download for free, in a range of languages, at [www.siemens.com/processinstrumentation/documentation](http://www.siemens.com/processinstrumentation/documentation)

# Flow Measurement

## SITRANS F C

### Flow sensor MC2

#### Dimensional drawings

Remote design, flanged construction, DIN EN/ANSI

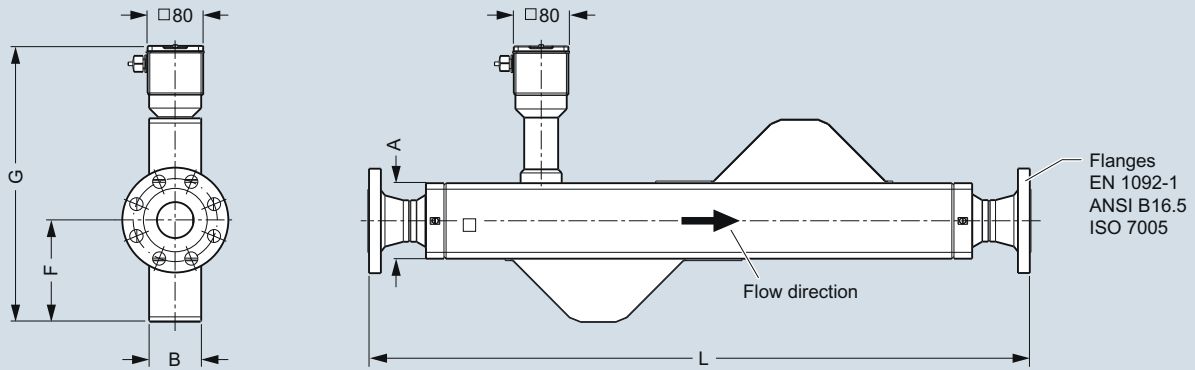

Meter size	Process connection size		L [mm (inch)]						G <sup>1)</sup> [mm (inch)]	F [mm (inch)]	B [mm (inch)]	A [mm (inch)]	Weight [kg (lb)]	
			DIN 11864-2 form A	EN 1092-1 PN 40	EN 1092-1 PN 100	ANSI B16.5 CL 150	ANSI B16.5 CL 300	ANSI B16.5 CL 600						
4	100	3	80	1618 (63.70)	1640 (64.57)	1680 (66.14)	1660 (65.35)	1680 (66.14)	1702 (67.01)	500 (19.69)	215 (8.46)	131 (5.16)	170 (6.69)	84 (185) 91 (201)
		4	100	1463 (57.60)	1480 (58.27)	1530 (60.24)	1500 (59.06)	1520 (59.84)	1568 (61.73)					
		6	150	N/A	1778 (69.92)	N/A	1806 (71.10)	1826 (71.89)	N/A					
6	150	6	150	N/A	2040 (80.31)	N/A	2070 (81.50)	2090 (82.28)	N/A	613 (24.13)	285 (11.22)	190 (7.84)	260 (9.84)	260 (573)

<sup>1)</sup> For Ex add 54 mm

Remote design, food industry fittings, DIN 11851

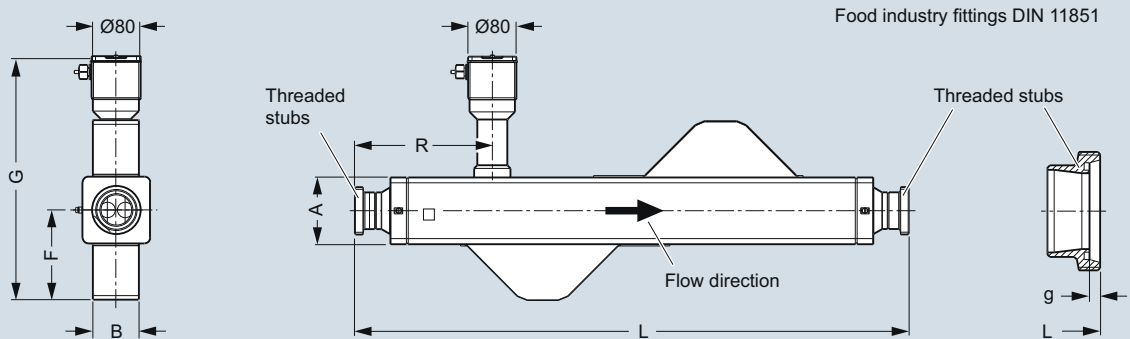

Meter size	Process connection size				L [mm (inch)]	g [mm (inch)]	G <sup>1)</sup> [mm (inch)]	F [mm (inch)]	B [mm (inch)]	A [mm (inch)]	R [mm (inch)]	Weight [kg (lb)]
	inch	DN	inch	DN								
4	100	3	80	Rd 110 x 1/6	1618 (63.70)	8 (0.31)	500 (19.69)	215 (8.46)	131 (5.16)	170 (6.69)	401 (15.79)	82 (180)
		4	100	Rd 130 x 1/4	1463 (57.60)	10 (0.39)					314 (12.36)	86 (190)

<sup>1)</sup> For Ex add 54 mm

Remote design, Tri-clamp DIN 32676 (ISO 2852)

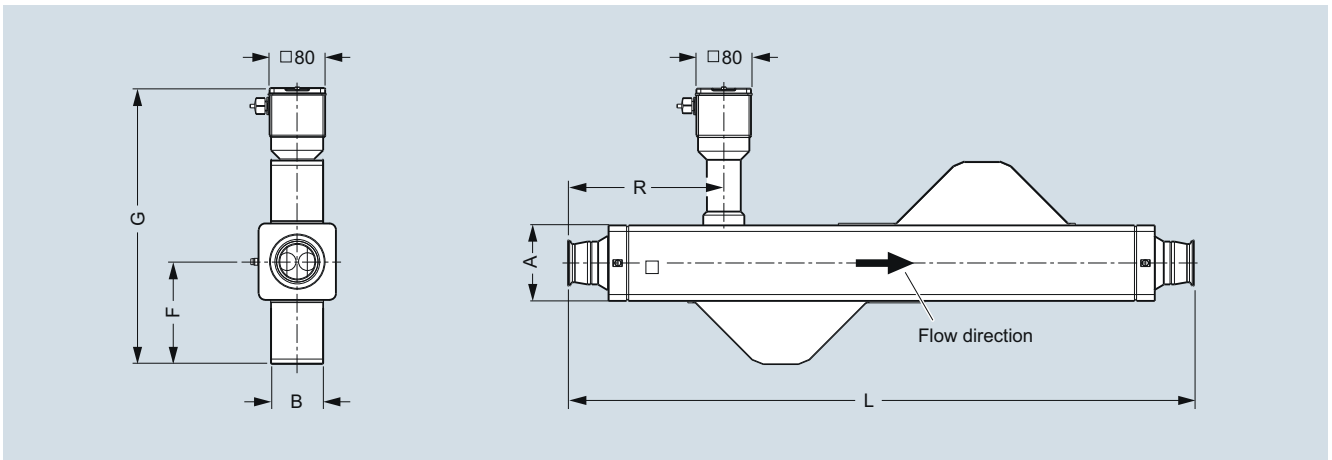

Dimensions in mm (inch)

Meter size		Process connection size		L [mm (inch)] ± 3	G <sup>1)</sup> [mm (inch)]	F [mm (inch)]	B [mm (inch)]	A [mm (inch)]	R [mm (inch)]	Weight [kg (lb)]
inch	DN	inch	DN							
4	100	3	80	1598 (62.91)	500 (19.69)	215 (8.46)	131 (5.16)	170 (6.69)	440 (17.32)	71 (157)
		4	100	1448 (57.01)						

<sup>1)</sup> For Ex add 54 mm

# Flow Measurement

## SITRANS F C

### Flow sensor MC2

#### Process Connections

- Flanges EN 1092-1/ANSI B16.5
- Tri-Clamp DIN 32676 (ISO 2852)  
- DN 100: Series 1
- Food Industry fittings DIN 11851

The max. allowable operating pressure is a function of the process connection type, the fluid temperature, the bolts and the gaskets.

#### Pressure Rating

- PN 16, PN 40  
Class 150, Class 300

#### Housing as secondary containment

- Max. 40 bar

#### Pressure Equipment Directive 97/23/EG

- Conformity evaluation category III, fluid group 1

Corrosion resistance of measuring pipe material to measuring medium has to be considered.

#### Material strength for process connections

Process connection	Size		PS <sub>max.</sub> at 20 °C (68 °F)	TS <sub>max.</sub>	TS <sub>min.</sub>
	DN	inch			
Thread acc. DIN 11851	100	4	25 (363)	140 (284)	-40 (-40)
Tri-Clamp acc. DIN 32676	100	4	10 (145)	120 (248)	-40 (-40)

#### Pressure/temperature curves

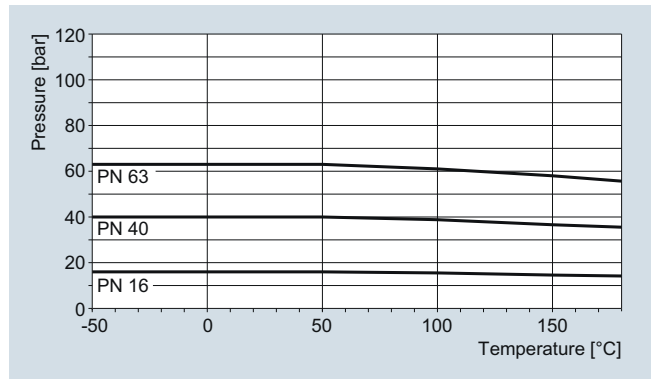

DIN-Flanges stainless steel AISI 316Ti/1.4571 to DN 100 (4")

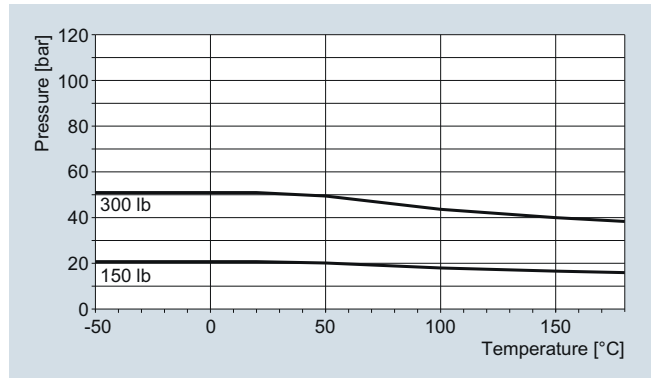

ASME-Flanges stainless steel AISI 326Ti/1.4571 to DN 100 (4")

For further information on the PED standard and requirements, see page 9/6.